

FREEMOTION®

t10.9 REFLEX

Model No. FMTL39818.0

Serial No. _____

Write the serial number in the space above for reference.

Serial Number Decal

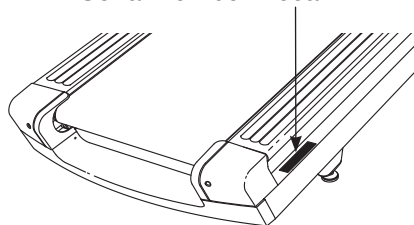

USER'S MANUAL

QUESTIONS?

If you have questions, or if parts are damaged or missing, please see HOW TO CONTACT CUSTOMER CARE on the back cover of this manual.

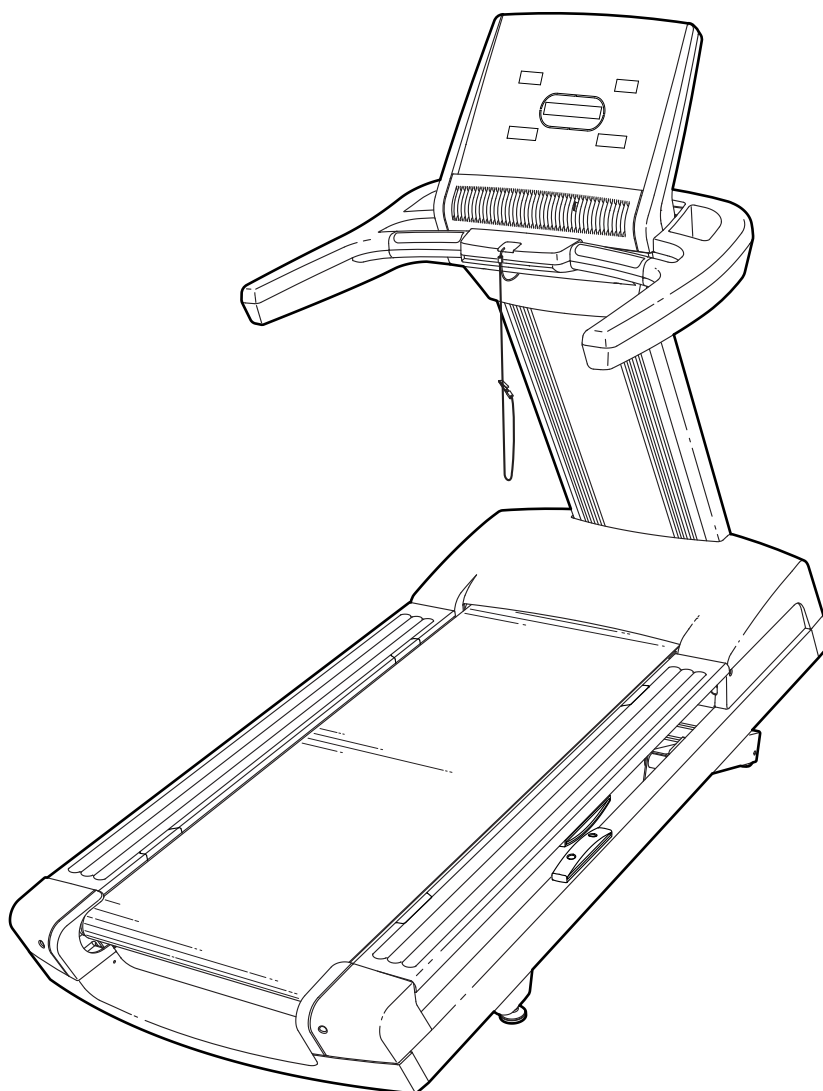

⚠ CAUTION

Read all precautions and instructions in this manual before using this equipment. Save this manual for future reference.

TABLE OF CONTENTS

WARNING DECAL PLACEMENT	3
IMPORTANT PRECAUTIONS	4
BEFORE YOU BEGIN	6
PART IDENTIFICATION CHART	7
ASSEMBLY	8
HOW TO USE THE TREADMILL	14
HOW TO USE THE CONSOLE	15
HOW TO MOVE THE TREADMILL	19
PREVENTIVE MAINTENANCE	20
PREVENTIVE MAINTENANCE RECORD	24
TROUBLESHOOTING	25
EXERCISE GUIDELINES	27
PART LIST	30
EXPLODED DRAWING	32
HOW TO CONTACT CUSTOMER CARE	Back Cover
LIMITED WARRANTY	Back Cover

WARNING DECAL PLACEMENT

CAUTION ATTENTION
 KEEP HANDS AND FEET AWAY FROM THIS AREA WHILE THE TREADMILL IS IN OPERATION.
 GARDEZ VOS PIEDS ET VOS MAINS ÉLOIGNÉS DE CET ENDROIT QUAND LE TAPIS ROULANT EST EN MARCHÉ.

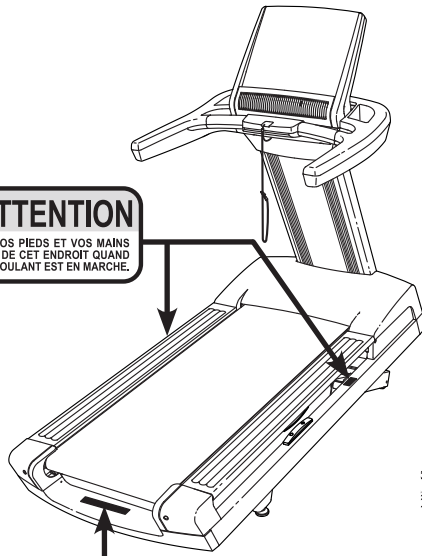

These drawings show the locations of the warning decals. If a decal is missing or illegible, see the back cover of this manual and request a free replacement decal. Apply the decal in the location shown. Note: The decals may not be shown at actual size.

WARNING
 • Hazardous Voltage
 • Risk of Electric Shock
 • Unplug Treadmill before Assembly/ Disassembly
ATTENTION
 • Tension Dangereuse
 • Risque de Choc Électrique
 • Débranchez le tapis roulant Avant l'Assemblage/Désassemblage

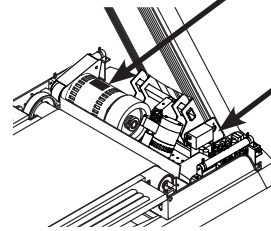

WARNING: Protect yourself and others from risk of serious injury. Read the user's manual or obtain proper instruction before use and: 

- Stand only on side rails when starting or stopping treadmill.
- Change speed in small increments.
- Hold handrails to prevent falling, and always wear the safety clip while operating treadmill.
- Stop if you feel faint, dizzy, or short of breath.
- Never allow children on or around treadmill.
- Remove key when not in use.
- Keep clothing, fingers, and hair away from moving belt.
- Never try to adjust or fix the belt while it is moving.
- Always wear athletic shoes while operating treadmill.





IMPORTANT PRECAUTIONS

⚠️ WARNING: To reduce the risk of burns, fire, electric shock, or injury to persons, read all important precautions and instructions in this manual and all warnings on your treadmill before using your treadmill. FreeMotion Fitness assumes no responsibility for personal injury or property damage sustained by or through the use of this product.

1. Before beginning this or any exercise program, consult your physician. This is especially important for persons over age 35 or persons with pre-existing health problems.
2. It is the responsibility of the owner to ensure that all users of this treadmill are adequately informed of all warnings and precautions.
3. The treadmill is not intended for use by persons with reduced physical, sensory, or mental capabilities or lack of experience and knowledge, unless they have been given supervision or instruction concerning use of the treadmill by someone responsible for their safety.
4. Use the treadmill only as described.
5. Keep the treadmill indoors, away from moisture and dust. Do not put the treadmill in a garage or covered patio, or near water.
6. Place the treadmill on a level surface, with at least 8 ft. (2.4 m) of clearance behind it and 2 ft. (0.6 m) on each side. Do not place the treadmill on any surface that blocks air openings. To protect the floor or carpet from damage, place a mat under the treadmill.
7. Do not operate the treadmill where aerosol products are used or where oxygen is being administered.
8. Keep children under age 13 and pets away from the treadmill at all times.
9. The treadmill should be used only by persons weighing 400 lbs. (181 kg) or less.
10. Never allow more than one person on the treadmill at a time.
11. Wear appropriate exercise clothes when using the treadmill. Do not wear loose clothes that could become caught in the treadmill. Athletic support clothes are recommended for both men and women. *Always wear athletic shoes. Never use the treadmill with bare feet, wearing only stockings, or in sandals.*
12. When connecting the power cord, follow the instructions on page 14. No other appliance should be on the same circuit as the treadmill. Do not use an extension cord.
13. Keep the power cord away from heated surfaces.
14. Never move the walking belt while the power is turned off. Do not operate the treadmill if the power cord or plug is damaged, or if the treadmill is not working properly. (See TROUBLESHOOTING on page 25 if the treadmill is not working properly.)
15. Read, understand, and test the emergency stop procedure before using the treadmill (see HOW TO TURN ON THE POWER on page 16). Always wear the clip while using the treadmill.
16. Always stand on the foot rails when starting or stopping the walking belt. Always hold the handrails while using the treadmill.
17. When a person is walking on the treadmill, the noise level of the treadmill will increase.
18. Keep fingers, hair, and clothing away from the moving walking belt.
19. The treadmill is capable of high speeds. Adjust the speed in small increments to avoid sudden jumps in speed.
20. Never leave the treadmill unattended while it is running. Always remove the key, press the power switch into the off position (see the drawing on page 6 for the location of the power switch), and unplug the power cord when the treadmill is not in use.

21. Do not move the treadmill until it is properly assembled (see **ASSEMBLY** on page 8). Do not move the treadmill by sliding it (see **HOW TO MOVE THE TREADMILL** on page 19). You must be able to safely lift 45 lbs. (20 kg) to move the treadmill.
22. Do not change the incline of the treadmill by placing objects under the treadmill.
23. Inspect and properly tighten all parts each time the treadmill is used.
24. Never insert or drop any object into any opening on the treadmill.
25. **DANGER:** Always unplug the power cord immediately after use, before cleaning the treadmill, and before performing the maintenance and adjustment procedures described in this manual. Never remove the motor hood unless instructed to do so by an authorized service representative. Servicing other than the procedures in this manual should be performed by an authorized service representative only.
26. Over exercising may result in serious injury or death. If you feel faint, if you become short of breath, or if you experience pain while exercising, stop immediately and cool down.

SAVE THESE INSTRUCTIONS

BEFORE YOU BEGIN

Thank you for selecting the revolutionary FREEMOTION® T 10.9 REFLEX treadmill. The T 10.9 REFLEX treadmill offers an impressive selection of features designed to make your workouts more effective and enjoyable.

For your benefit, read this manual carefully before using the treadmill. If you have questions after

reading this manual, please see the back cover of this manual. To help us assist you, note the product model number and serial number before contacting us. The model number and the location of the serial number decal are shown on the front cover of this manual.

Before reading further, please review the drawing below and familiarize yourself with the labeled parts.

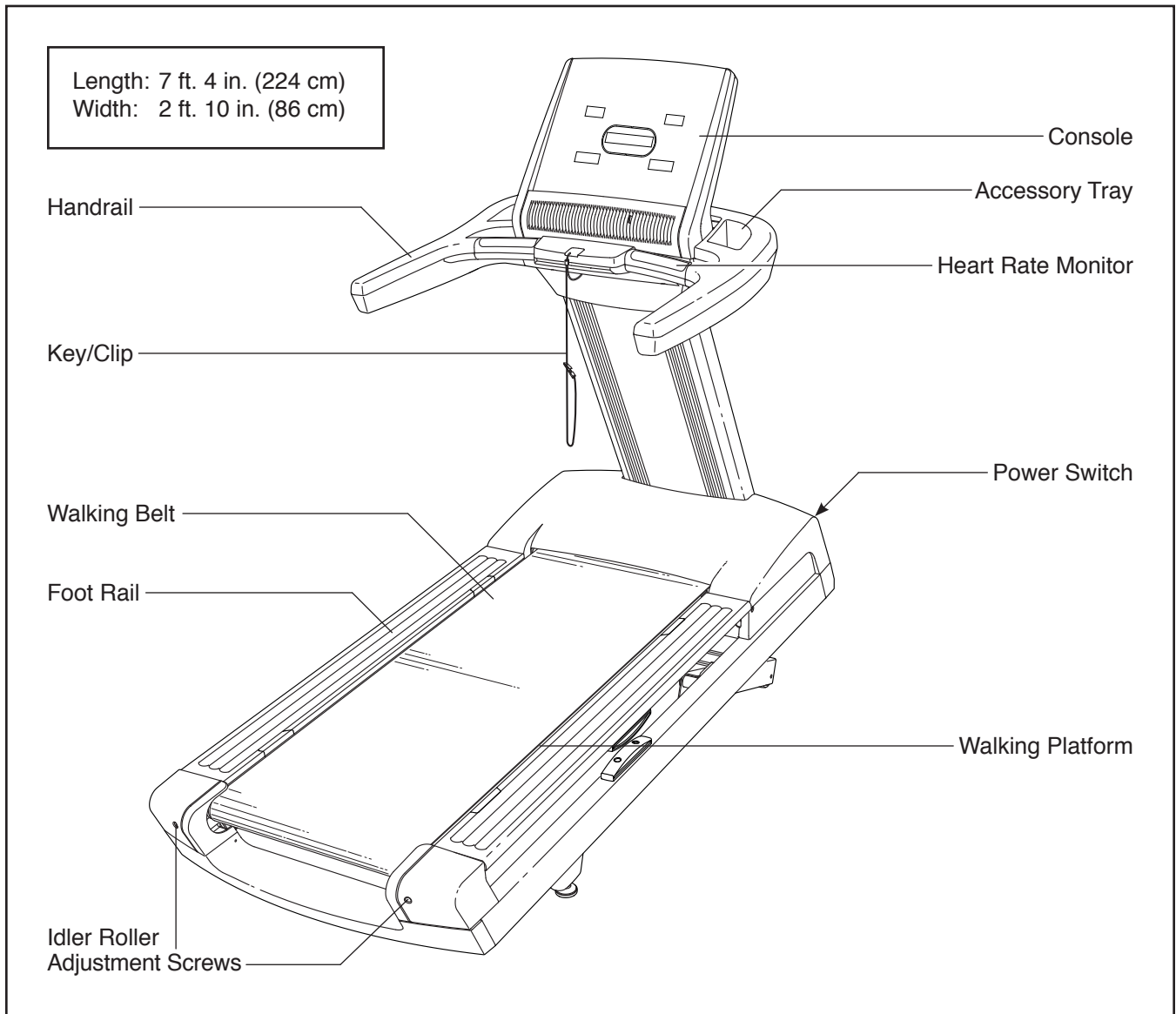

PART IDENTIFICATION CHART

Use the drawings below to identify small parts used for assembly. The number in parentheses below each drawing is the key number of the part, from the PART LIST near the end of this manual. The number following the key number is the quantity used for assembly. **Note: If a part is not in the hardware kit, check to see whether it is preattached. Extra hardware may be included.**

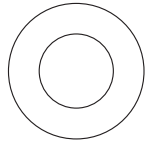

3/8" Flat Washer (43)-4

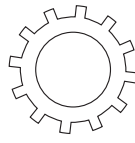

3/8" Star Washer (2)-6

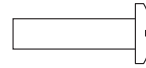

#8 x 5/8" Screw (18)-2

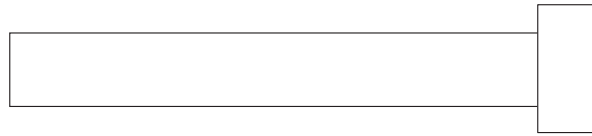

3/8" x 2 3/4" Screw (27)-4

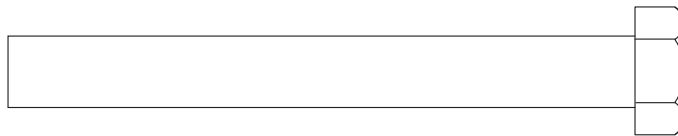

3/8" x 3 1/4" Screw (1)-4

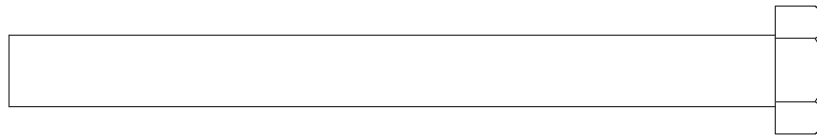

3/8" x 4" Screw (11)-4

ASSEMBLY

- Assembly requires two persons.
- Place all parts in a cleared area and remove the packing materials. Do not dispose of the packing materials until you finish all assembly steps.
- To identify small parts, see page 7.
- After shipping, there may be an oily substance on the exterior of the treadmill. This is normal. If there is an oily substance on the treadmill, wipe it off with a soft cloth and a mild, non-abrasive cleaner.

- Assembly requires the following tools:

one set of English hex keys 

one adjustable wrench 

one Phillips screwdriver 

To avoid damaging parts, do not use power tools.

1. **Make sure that the power cord is unplugged. Be careful not to pinch the power cord.**

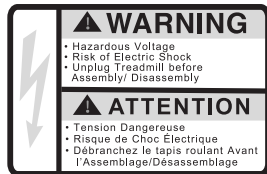

Slide the Upright Cover (not shown) off the Upright (81).

Orient the Upright (81) and the plastic ties (A) as shown. Set the Upright on the tabs (B) on the Frame (53). Then, attach the Upright with four 3/8" x 3 1/4" Screws (1), two 3/8" Star Washers (2), and two 3/8" Flat Washers (43); **start all four Screws, and then torque them to 20 pound-feet (27 Newton-meters). Do not pinch any wires.**

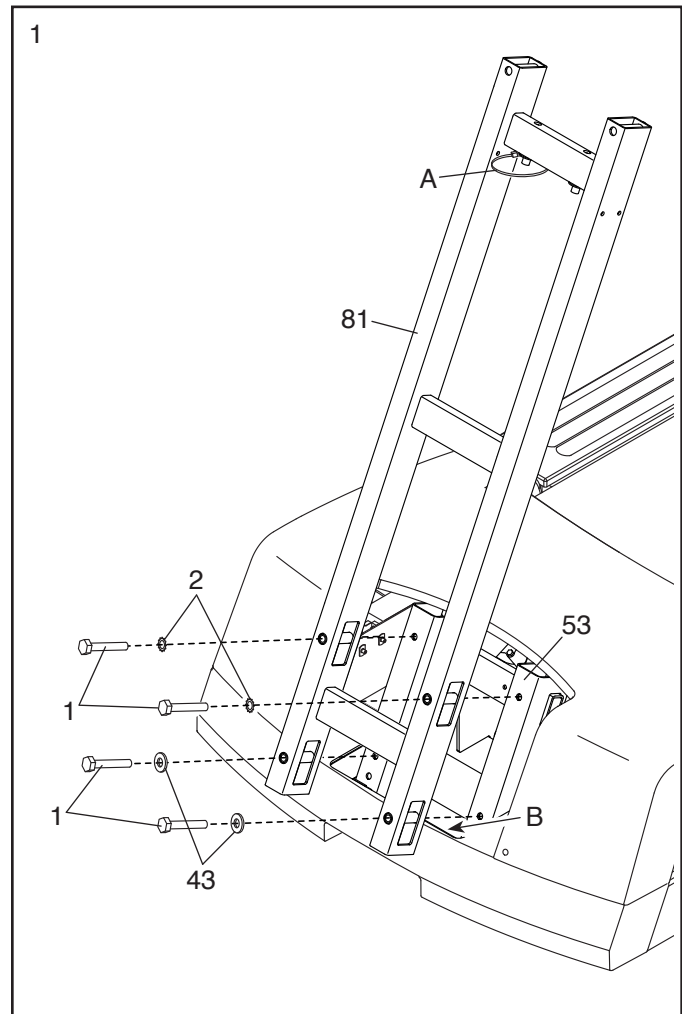

2. Insert the end of the Upright Wire (111) through the looped plastic tie (A) at the top of the Upright (81). **Make sure that the Upright Wire is behind the crossbars (C) on the Upright.** Then, gently pull upward on the Upright Wire as you tighten the plastic tie around the Upright Wire.

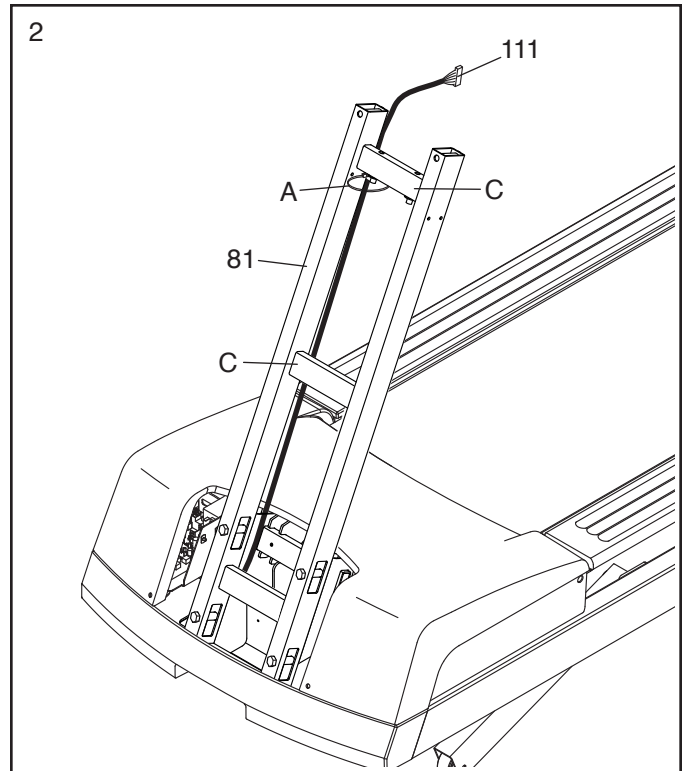

3. Slide the Upright Cover (80) downward onto the Upright (81). **Do not pinch the Upright Wire (111). Make sure not to hit the ceiling with the Upright Cover.**

Next, orient the Upright Collar (105) so that the sticker (D) is on the indicated side. Slide the Upright Collar onto the Upright Cover (80).

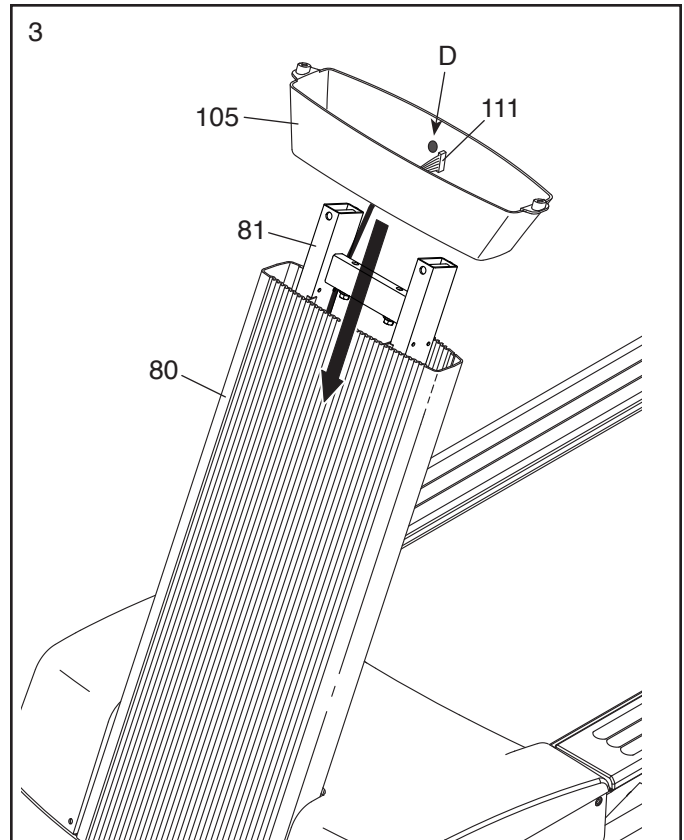

4. Have a second person hold the handrail assembly (E) near the Upright (81). Insert the Upright Wire (111) upward through the center of the handrail assembly.

Then, slide the bracket (F) on the handrail assembly (E) over the crossbar (C) on the Upright (81), and set the handrail assembly on the Upright. **Do not pinch any wires.**

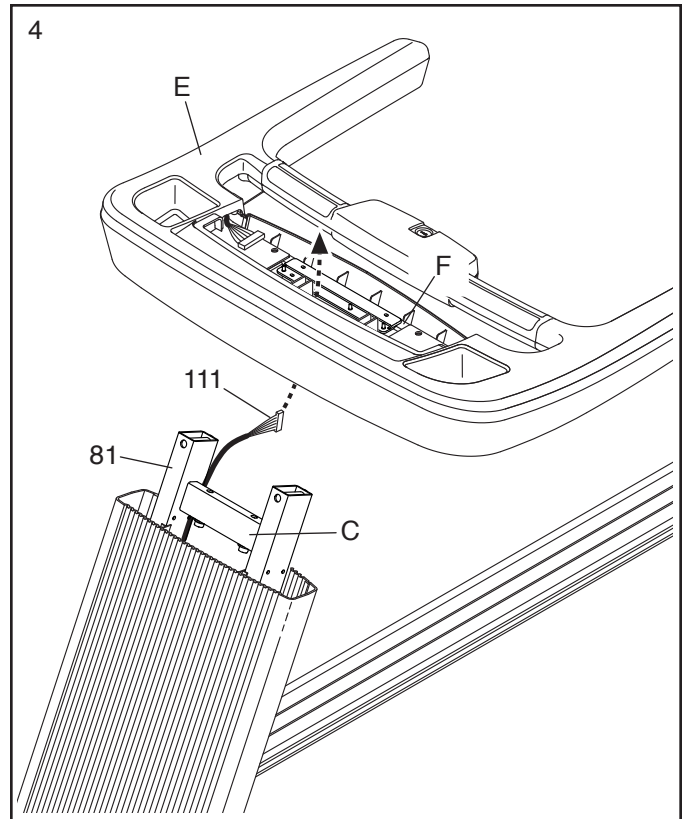

5. Attach the handrail assembly (E) with two 3/8" x 4" Screws (11) and two 3/8" Star Washers (2); **do not fully tighten the Screws yet. Do not pinch any wires.**

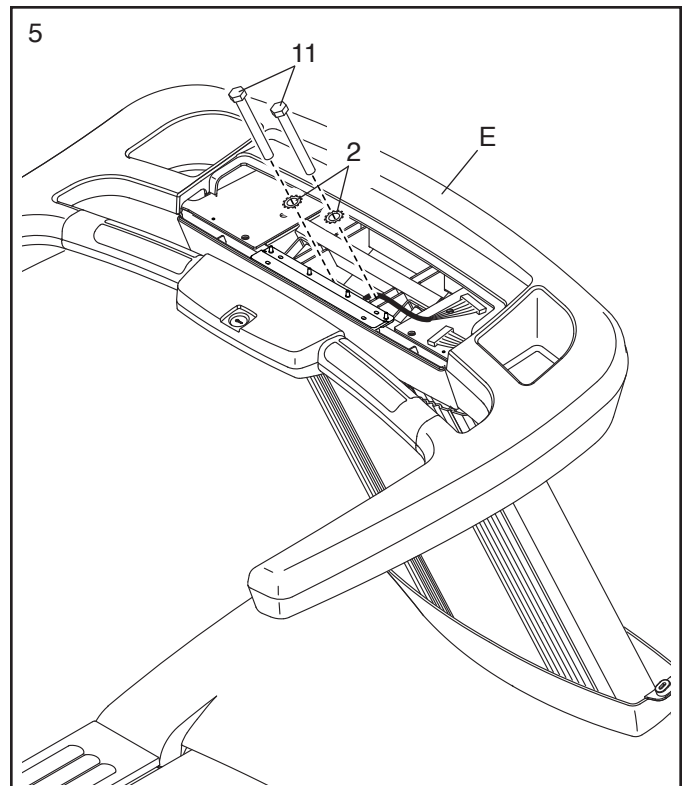

6. Tighten two 3/8" x 4" Screws (11) with two 3/8" Flat Washers (43) into the handrail assembly (E); **start both Screws, and then torque them to 20 pound-feet (27 Newton-meters).**

See step 5. Torque the two 3/8" x 4" Screws (11) to 20 pound-feet (27 Newton-meters).

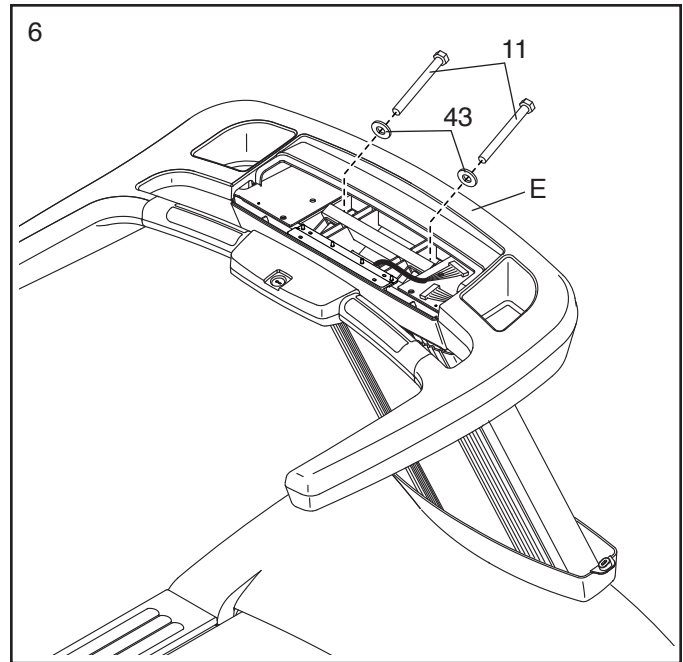

7. Have a second person hold the Console Assembly (101) near the handrail assembly (E).

See the inset drawing. Connect the Upright Wire (111) and the handrail wire (G) to the console wires (H). Make sure that the console wire and the handrail wire that you are connecting have connectors that are the same size. **The connectors should slide together easily and snap into place.** If they do not, turn one connector and then try again. **IF THE CONNECTORS ARE NOT CONNECTED PROPERLY, THE CONSOLE MAY BE DAMAGED WHEN THE POWER IS TURNED ON.**

Next, insert the excess wires downward into the Upright Cover (80).

Then, set the Console Assembly (101) on the handrail assembly (E). **Do not pinch any wires.**

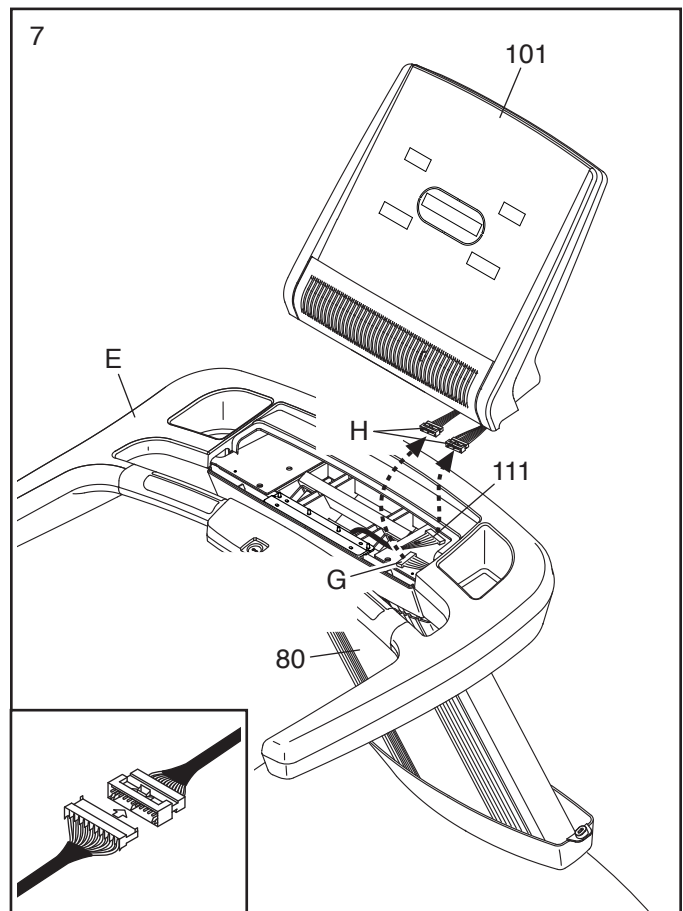

8. Tighten four 3/8" x 2 3/4" Screws (27) with two 3/8" Star Washers (2) into the handrail assembly (E).

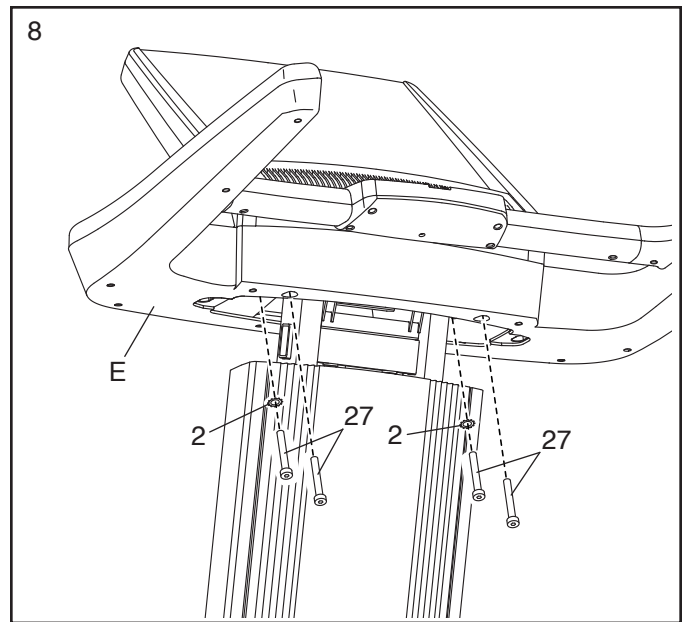

9. Attach the Upright Collar (105) to the handrail assembly (E) with two #8 x 5/8" Screws (18).

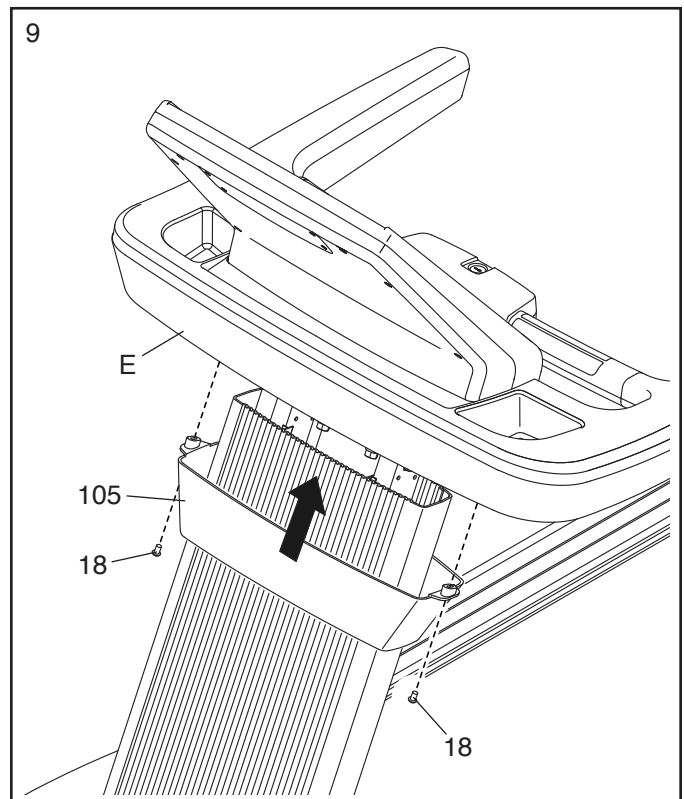

10. If necessary, move the treadmill to the desired location. **IMPORTANT: Before moving the treadmill, see HOW TO MOVE THE TREADMILL on page 19.**

After the treadmill is placed in the location where it will be used, make sure that the Leveling Feet (64) rest firmly on the floor. If the treadmill rocks even slightly, turn the nut on a Leveling Foot clockwise or counterclockwise until the rocking motion is eliminated.

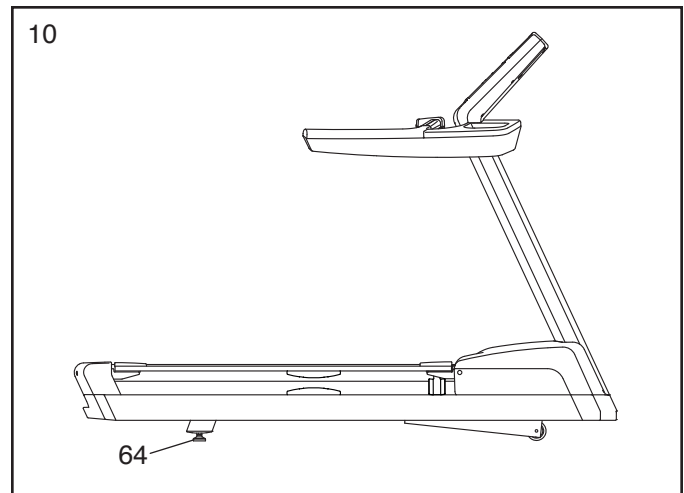

11. **Make sure that all parts are properly tightened before you use the treadmill.** If there are sheets of plastic on the treadmill decals, remove the plastic. To protect the floor or carpet, place a mat under the treadmill. To avoid damage to the console, keep the treadmill out of direct sunlight. Note: Extra hardware may be included.

HOW TO USE THE TREADMILL

⚠ DANGER: Improper connection of the equipment-grounding conductor increases the risk of electric shock. Check with a qualified electrician or serviceman if you are unsure whether the product is properly grounded. Do not modify the plug—if it will not fit the outlet, have a proper outlet installed by a qualified electrician. Do not use an adapter to connect the plug to an improper receptacle.

HOW TO CONNECT THE POWER CORD

This product must be grounded. If it should malfunction or break down, grounding provides a path of least resistance for electric current to reduce the risk of electric shock.

This product is for use on a dedicated, 20-amp, 120-volt circuit. No other appliance should be on the same circuit. This product has a cord with an equipment-grounding conductor and a grounding plug.

Plug the grounding plug into a standard NEMA 5-20 receptacle. Do not modify the plug or the receptacle. Do not use an adapter, a surge protector, or an extension cord. The receptacle must be grounded.

WARRANTY INFORMATION

The warranty for this product does not cover damage or equipment failure caused by electric wiring not in compliance with electrical codes or the specifications in this manual, or failure to provide reasonable and necessary maintenance as outlined in this manual. Any failure or damage caused by unauthorized service; misuse; accident; negligence; improper assembly or installation; debris resulting from any destruction activities in the product's environment; rust or corrosion as a result of the product's location; alterations or modifications without written authorization; or failure on your part to use, operate, and maintain the product as set forth in this manual will void the warranty.

All terms of the warranty are void if this product is moved beyond the continental borders of the United States of America (excluding Alaska, Hawaii, and Canada) and are then subject to the terms provided by that country's local authorized FreeMotion Fitness, Inc. representative.

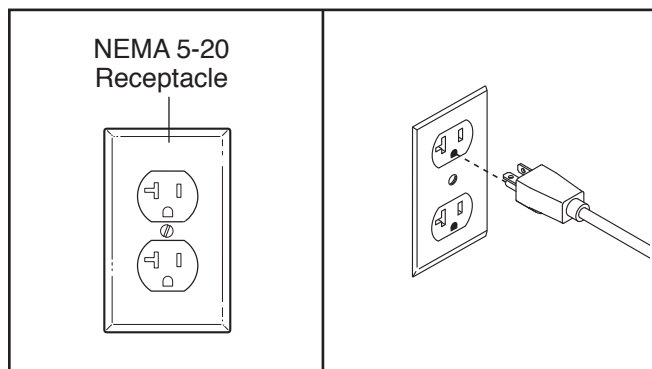

HOW TO USE THE CONSOLE

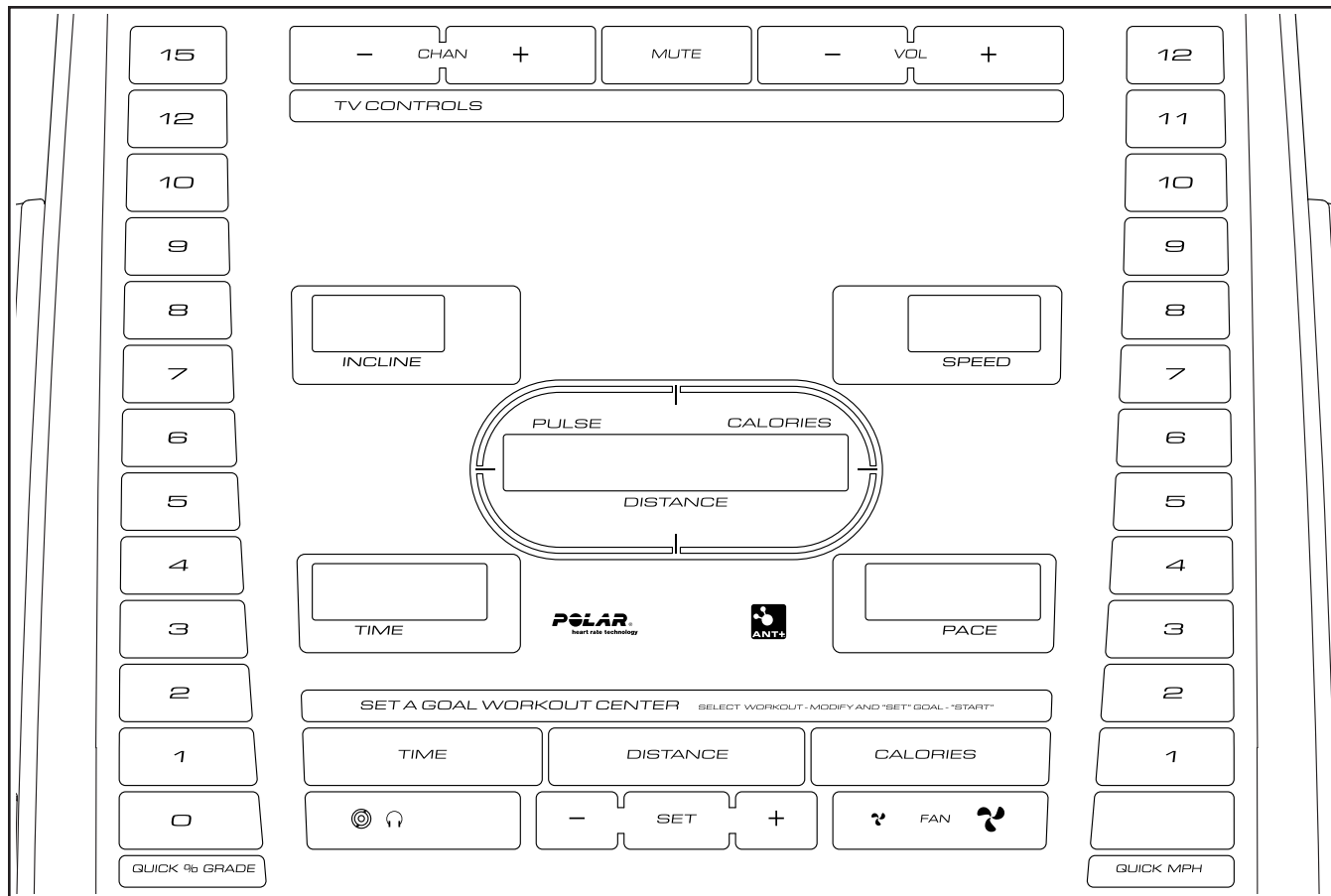

FEATURES OF THE CONSOLE

The treadmill console offers a selection of features designed to make your workouts more effective and enjoyable. You can change the speed and incline of the treadmill with the touch of a button. As you exercise, the console will display instant exercise feedback. You can also measure your heart rate using the handgrip heart rate monitor.

In addition, the console features a selection of set-a-goal workouts. You can set a time, distance, or calorie goal to reach by the end of your workout.

To turn on the power, see page 16. **To use the manual mode,** see page 16. **To use a set-a-goal workout,** see page 17. **To use the maintenance mode,** see page 18.

Note: The console can display speed and distance in either miles or kilometers. To find which unit of measurement is selected, see THE MAINTENANCE MODE on page 18. For simplicity, all instructions in this manual refer to miles.

IMPORTANT: If there are sheets of plastic on the console, remove the plastic. To prevent damage to the walking platform, wear clean athletic shoes while using the treadmill. The first time you use the treadmill, observe the alignment of the walking belt, and center the walking belt if necessary (see page 25).

HOW TO TURN ON THE POWER

IMPORTANT: If the treadmill has been exposed to cold temperatures, allow it to warm to room temperature before you turn on the power. If you do not do this, you may damage the console displays or other electrical components.

Plug in the power cord (see page 14). Next, locate the power switch on the treadmill frame near the power cord. Press the power switch into the on position.

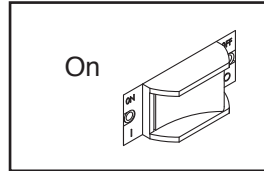

Next, stand on the foot rails of the treadmill. Find the clip attached to the key and attach the clip onto the waistband of your clothes. Then, insert the key into the console. After a moment, the displays will light.

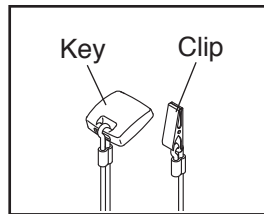

IMPORTANT: In an emergency, the key can be pulled from the console, causing the walking belt to slow to a stop. Test the clip by carefully taking a few steps backward; if the key is not pulled from the console, adjust the position of the clip.

HOW TO USE THE MANUAL MODE

1. Insert the key into the console.

See HOW TO TURN ON THE POWER at the left.

2. Enter your weight if desired.

First, press the Set button. Next, use the increase and decrease buttons next to the Set button to adjust the weight shown in the display. Then, press the Set button to save the weight you entered.

3. Start the walking belt.

To start the walking belt, press the Start button. The walking belt will begin to move at 1 mph. As you exercise, change the speed of the walking belt as desired by pressing the Speed increase and decrease buttons. Each time you press one of the buttons, the speed setting will change by 0.1 mph; if you hold down the button, the speed setting will change in increments of 0.5 mph. Note: After you press the button, it may take a moment for the walking belt to reach the selected speed setting.

If you press one of the numbered Speed buttons, the walking belt will gradually change speed until it reaches the selected speed setting.

To pause the walking belt, press the Pause button. The time will begin to flash in the display. To restart the walking belt, press the Start button.

4. Change the incline of the treadmill as desired.

To change the incline of the treadmill, press the Incline increase or decrease button or one of the numbered Incline buttons. Each time you press one of the buttons, the treadmill will gradually adjust to the selected incline setting.

5. Follow your progress with the displays.

The matrix—The matrix will display a track that represents 1/4 mile (400 meters). As you exercise, the indicators around the track will appear in succession until the entire track appears. The track will then disappear and the indicators will again begin to appear in succession.

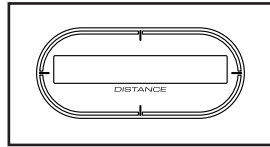

The Incline display—This display will show the incline of the treadmill.

The Time display—This display will show the elapsed time.

The Distance display—This display will show the distance that you have walked or run.

The Speed display—This display will show the speed of the walking belt.

The Pace display—This display will show your pace.

To reset the displays, press the Stop button, remove the key, and then reinsert the key. Note: If the treadmill is not used for a few minutes, the displays will reset automatically.

6. Measure your heart rate if desired.

Before using the handgrip heart rate monitor, remove the sheets of plastic from the metal contacts. In addition, make sure that your hands are clean.

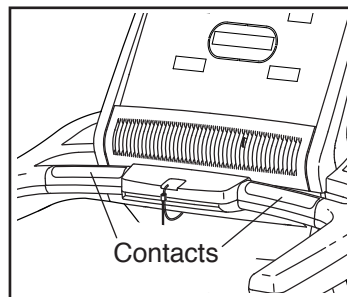

To measure your heart rate, **stand on the foot rails** and hold the contacts with your palms for approximately ten seconds; **avoid moving your hands**. When your pulse is detected, your heart rate will be shown. **For the most accurate heart rate reading, continue to hold the contacts for about 15 seconds.**

7. Turn on the fan if desired.

The fan features several speed settings and an auto mode. When the auto mode is selected, the speed of the fan will automatically increase and decrease as the speed of the walking belt increases and decreases.



Press the fan increase or decrease button to select a fan speed or to turn off the fan. Note: If the fan is on when the walking belt is stopped, the fan will turn off automatically after a few minutes.

8. When you are finished exercising, press the Stop button.

Press the Stop button, and run on the treadmill until the walking belt slows to a stop.

HOW TO USE A SET-A-GOAL WORKOUT

1. Insert the key into the console.

See HOW TO TURN ON THE POWER on page 16.

2. Enter your weight if desired.

See step 2 on page 16.

3. Set a time, distance, or calorie goal.

To select a set-a-goal workout, press the Time, Distance, or Calories button. Use the increase and decrease buttons below the Time, Distance, and Calories buttons to adjust the goal amount. Then, press the Set button to set the goal.

4. Start the workout.

Press the Start button to start the workout. A moment after you press the button, the walking belt will begin to move. Hold the handrails and begin walking.

The workout will function in the same way as the manual mode (see page 16).

The workout will continue until you reach the goal that you set. The treadmill will then enter cool down mode, after which the walking belt will slow to a stop.

Note: The calorie goal is an estimate of the number of calories that you will burn during the workout. The actual number of calories that you burn will depend on various factors such as your weight.

5. Follow your progress with the displays.

See step 5 on page 17.

6. Measure your heart rate if desired.

See step 6 on page 17.

7. Turn on the fan if desired.

See step 7 on page 17.

8. When you are finished exercising, remove the key from the console.

See step 8 on page 17.

THE MAINTENANCE MODE

The console features a maintenance mode that keeps track of treadmill information and allows you to personalize console settings.

To select the maintenance mode, hold down the Stop button while inserting the key into the console, and then release the Stop button. When the maintenance mode is selected, press the Stop button to access the optional screens. Then, press the Incline increase button to change settings.

UNITS—This display will show which unit of measurement is selected. To view distance in miles, select UNITS ENGLISH. To view distance in kilometers, select UNITS METRIC.

CALIBRATE INCL—This display is used to calibrate the incline system. To calibrate the incline system, press the Incline increase and decrease buttons.

TOTAL TIME—This display will show the total number of hours that the treadmill has been used.

TOTAL DISTANCE—This display will show the total number of miles or kilometers that have been run on the treadmill.

FAN AUTO—This display allows you to adjust the default setting for the fan when the walking belt is moving.

PAUSE TIME—This display allows you to adjust the amount of time that will pass before the console will reset the displays after the walking belt has been paused.

IDLE TIME—This display allows you to adjust the amount of time that will pass before the console goes to sleep after no buttons have been pressed.

BELT TIME—This display will show the total number of hours that the walking belt has moved.

BELT DISTANCE—This display will show the total number of miles or kilometers that the walking belt has moved.

Note: There are several other optional screens in the maintenance mode meant to provide information about the treadmill to service technicians.

To exit the maintenance mode, remove the key from the console.

HOW TO MOVE THE TREADMILL

IMPORTANT: Due to the size and weight of the treadmill, moving it requires two or three persons. To avoid damaging the leveling feet, do not move the treadmill by sliding it.

Before moving the treadmill, plug in the power cord, insert the key into the console, and raise the incline to the highest position (see pages 14 to 16). Next, **remove the key and unplug the power cord.** Then, follow the steps below.

1. Hold the handle firmly. **CAUTION: To decrease the possibility of injury or of damage to the treadmill, do not lift the treadmill by the hand-rail.** Raise the handle until the treadmill will roll on the wheels. Then, carefully roll the treadmill to the desired location and lower it to the level position. **CAUTION: To reduce the risk of injury, use extreme caution while moving the treadmill. Do not attempt to move the treadmill over uneven surfaces.**

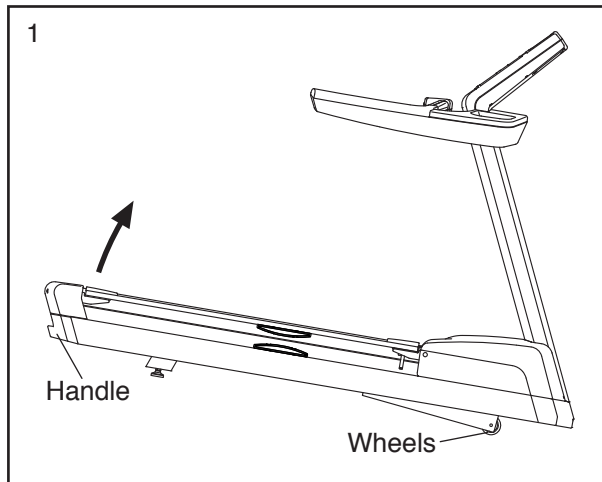

2. When the treadmill is in the location where it will be used, make sure that the leveling feet rest firmly on the floor. If the treadmill rocks even slightly, turn the nut on a leveling foot clockwise or counter-clockwise until the rocking motion is eliminated.

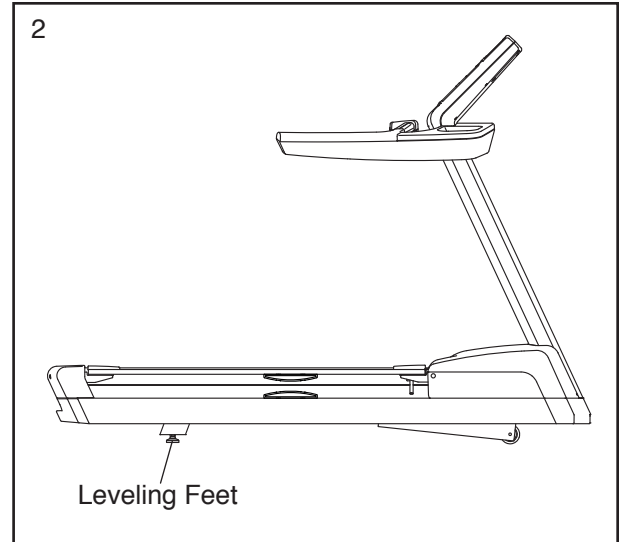

PREVENTIVE MAINTENANCE

Regular maintenance is necessary for optimal performance and long life of the treadmill. Please read and follow all instructions below. If you have questions, see the back cover of this manual.

⚠ WARNING: If all maintenance procedures are not performed as described, components may wear excessively, the treadmill may become damaged, a risk of injury or a risk of fire may result, and the warranty will be voided.

WEEKLY MAINTENANCE

1. **Remove the key and unplug the power cord.** Inspect and properly tighten all external parts of the treadmill.
2. Apply a mild multi-purpose cleaner to a 100% cotton cloth and remove any dust and grime from the handrails, upright, foot rails, frame, and motor hood. In addition, wipe the walking platform along the sides of the walking belt; **do not wipe under the walking belt.** Then, apply a small amount of the cleaner to a second cloth and wipe the console and screen(s). **Do not spray cleaner directly onto the treadmill or use ammonia or acid-based cleaners.**
3. Vacuum the area around the treadmill.
4. Make sure that the walking belt is centered and properly tightened. If it is centered and runs smoothly when a person is running on the treadmill, do not make any adjustments. If the walking belt needs to be adjusted, see pages 23 and 26.

MONTHLY MAINTENANCE

1. **Remove the key and unplug the power cord.** Next, remove the two indicated 5/16" x 1/2" Screws (16), and lift off the Motor Hood (66).

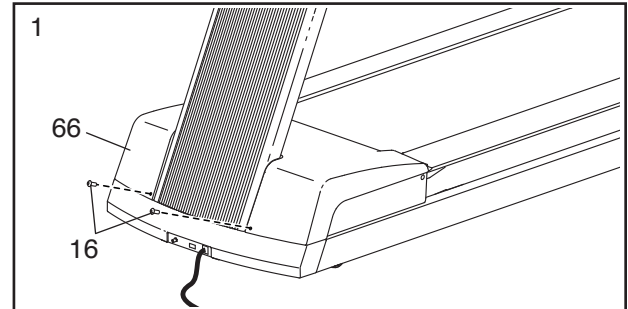

2. Using a hand-held vacuum, clean the area that was under the motor hood.

Be careful to avoid touching any components. Then, check the Motor Belt (57) for wear, cracks, dust buildup, and proper tension. If the Motor Belt needs to be replaced, see the back cover of this manual.

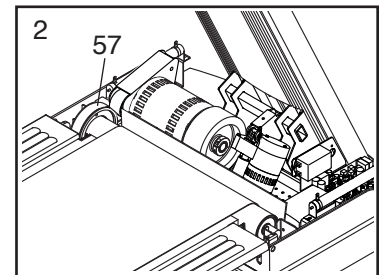

3. Lift the edge of the walking belt and slide your hand between the walking belt and the walking board. If the underside of the walking belt is dry, you may need to apply more lubricant (see the back cover of this manual).
4. Plug in the power cord and insert the key into the console. Then, press the Start button. **Be careful to avoid injury; keep your hands away from moving parts and make sure that your clothes cannot become caught in moving parts.** While the walking belt is moving, check the treadmill for unusual noises or odors. If any of these problems exists, see the back cover of this manual.

Remove the key and unplug the power cord. See step 1. Reattach the Motor Hood (66) with the 5/16" x 1/2" Screws (16).

REPLACING THE WALKING PLATFORM AND THE WALKING BELT

Inspect the walking platform periodically for wear. If there is any wood showing through the phenolic coating, or if the surface is damaged, the walking platform should be turned over or replaced. In addition, inspect the walking belt for wear. If the walking belt is cracking, tearing, or folding, it should be replaced. Follow the instructions below to turn over or replace the walking platform and/or to replace the walking belt. **As you remove screws, make sure to note which screws you remove from each part.**

1. Remove the key and unplug the power cord.

Next, remove the two indicated 5/16" x 1/2" Screws (16), and lift off the Motor Hood (66).

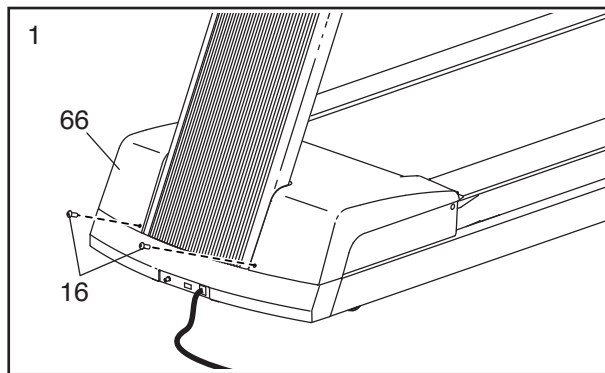

2. Remove the four indicated 1/4" x 3/4" Screws (35) and the two 1/4" x 1/2" Screws (138). Then, remove the Rear Cap (59).

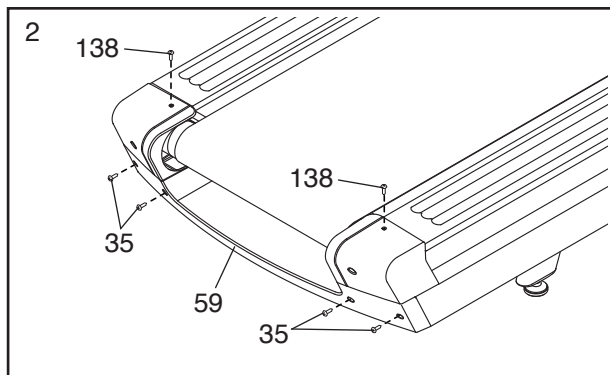

3. Remove the two 1/4" x 3/4" Cap Screws (15), the two 3/8" Hairpin Cotter Pins (26), the two 3/8" Pins (14), and the two 3/8" Washers (32).

Next, remove the two 3/8" x 3" Screws (7), the two 3/8" Lock Washers (not shown), and the two 3/8" Washers (not shown).

Then, remove the Drive Roller (113) and the Idler Roller (63).

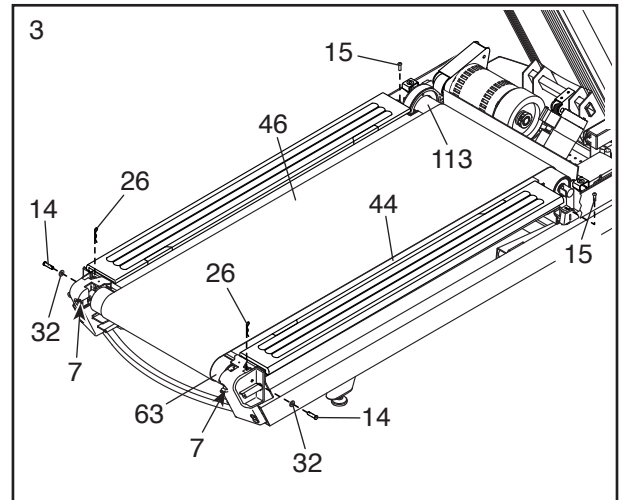

If you are turning over or replacing the Walking Platform (44), go to step 4.

If you are replacing only the Walking Belt (46), remove the old Walking Belt and discard it.

Next, slide the new Walking Belt onto the Walking Platform (44). Then, carefully follow steps 1–3 in reverse order. Turn both 3/8" x 3" Screws (7) clockwise **only four turns**. Then, go to step 6.

4. Carefully lift the back end of each Foot Rail (114) until it detaches from the Walking Platform (44). Slide the Foot Rails off the end of treadmill.

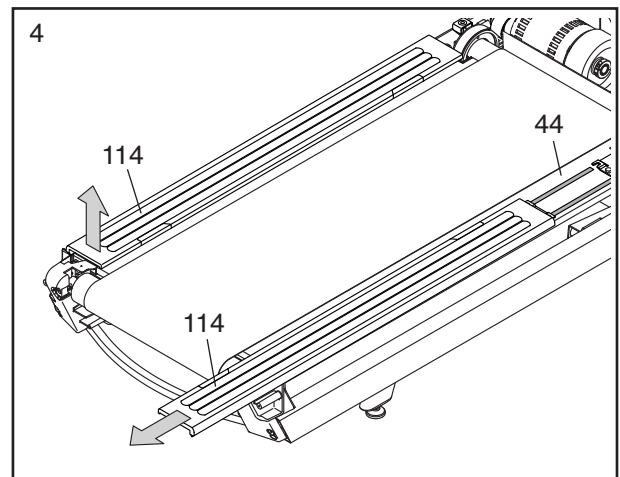

- Remove the Walking Belt (46) and the Walking Platform (44) from the treadmill. Next, remove the Walking Belt from the Walking Platform. Then, remove the eight 3/8" Nuts (34) and the eight 3/8" x 1 3/4" Bolts (5), and slide the Rear and Front Platform Brackets (47, 48) off the Walking Platform.

Next, remove the four #16 x 1 1/2" Screws (51) and the two Platform Cushions (134).

Remove the twelve #8 x 1/2" Wood Screws (12) and the six Foot Rail Brackets (148). Then, peel off and save the four Foot Rail Pads (85).

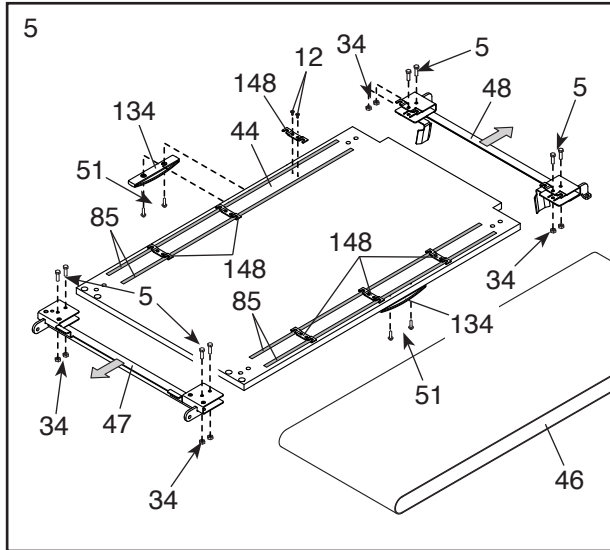

Check to see whether both sides of the Walking Platform (44) are worn. If the underside has not previously been used, you can turn over the Walking Platform and continue to use it. If the Walking Platform has previously been turned over, discard the old Walking Platform. **Save all other parts.**

Using the new Walking Platform (44) or the old Walking Platform with the unworn side facing upward, carefully follow steps 1–5 in reverse order. If you are also replacing the Walking Belt (46), use the new Walking Belt. Turn the 3/8" x 3" Screws (7) (see step 3) clockwise **only four turns. Then, go to step 6.**

- Lift the right or left edge of the Walking Belt (46) and look for a small arrow printed on the underside of the Walking Belt; move the Walking Belt, if necessary, as you look for an arrow. **If you find an arrow, make sure that the arrow is pointing toward the rear of the treadmill, as shown.** If it is not, remove the Walking Belt, turn it around, and slide it back onto the Walking Platform (44). Note: Your walking belt may not have an arrow. If it does not have an arrow, it can be turned either way.

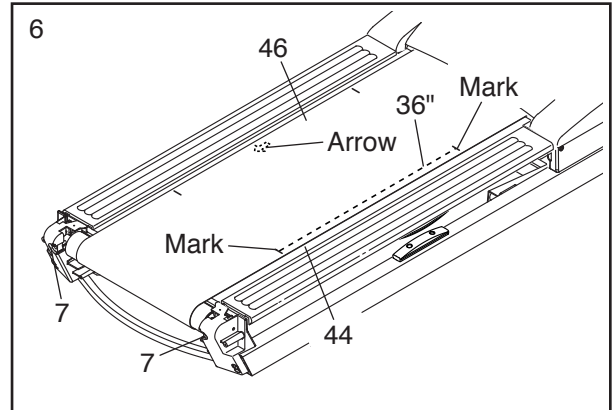

Next, move the Walking Belt (46), if necessary, until the seam (not shown) across the Walking Belt is beneath the Walking Platform (44).

Then, locate the indicated marks on the left and right sides of the Walking Belt (46). The inside edges of both marks should be exactly 36" apart. If necessary, turn both 3/8" x 3" Screws (7) clockwise or counterclockwise until the marks are exactly 36" apart.

7. Center the Walking Belt (46), if necessary (see page 25). Then, plug in the power cord, step onto the foot rails, insert the key into the console, and press the Start button. Hold the handrails and gently press one foot against the moving Walking Belt. If the Walking Belt stops moving, **remove the key from the console, unplug the power cord,** and turn the two 3/8" x 3" Screws (7) clockwise one turn. Continue to test the tension of the Walking Belt until the Walking Belt no longer slips. Make sure to keep the Walking Belt centered. **If the Idler Roller (63) stops turning, do not further tighten the Screws; please see the back cover of this manual.**

LUBRICATING THE WALKING BELT

Your treadmill features a walking belt coated with high-performance lubricant. **IMPORTANT: Never apply silicone spray or other substances to the walking belt or the walking platform unless instructed to do so by an authorized service representative.**

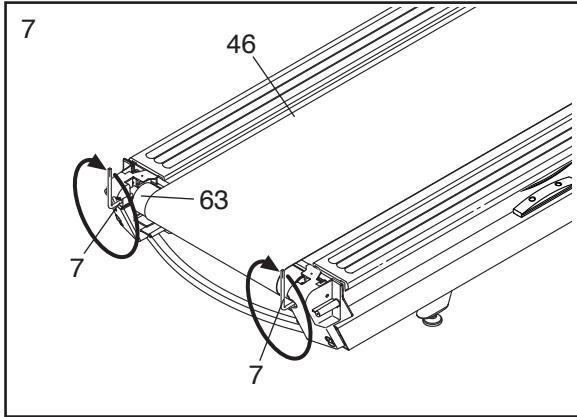

PREVENTIVE MAINTENANCE RECORD

Photocopy this form and use it to record the preventive maintenance performed on the treadmill. Each copy of the form can be used for six months (26 weeks). When maintenance is performed, write the date in the appropriate spaces. **IMPORTANT: Perform all maintenance procedures as described on pages 20 to 23. If all procedures are not performed as described, components may wear excessively, the treadmill may become damaged, a risk of injury or a risk of fire may result, and the warranty will be voided.**

	Weekly Maintenance			Monthly Maintenance		
	Inspect and tighten all external parts of the treadmill.	Clean the treadmill, and vacuum the area around the treadmill.	Check the walking belt for proper tension and alignment.	Remove the motor hood and vacuum the motor compartment.	Check the motor belt for wear, and check the walking belt for lubricant.	Check the motor for arcing, and check for noises or odors.
Week 1	/ /	/ /	/ /			
Week 2	/ /	/ /	/ /			
Week 3	/ /	/ /	/ /			
Week 4	/ /	/ /	/ /	/ /	/ /	/ /
Week 5	/ /	/ /	/ /			
Week 6	/ /	/ /	/ /			
Week 7	/ /	/ /	/ /			
Week 8	/ /	/ /	/ /	/ /	/ /	/ /
Week 9	/ /	/ /	/ /			
Week 10	/ /	/ /	/ /			
Week 11	/ /	/ /	/ /			
Week 12	/ /	/ /	/ /			
Week 13	/ /	/ /	/ /	/ /	/ /	/ /
Week 14	/ /	/ /	/ /			
Week 15	/ /	/ /	/ /			
Week 16	/ /	/ /	/ /			
Week 17	/ /	/ /	/ /	/ /	/ /	/ /
Week 18	/ /	/ /	/ /			
Week 19	/ /	/ /	/ /			
Week 20	/ /	/ /	/ /			
Week 21	/ /	/ /	/ /	/ /	/ /	/ /
Week 22	/ /	/ /	/ /			
Week 23	/ /	/ /	/ /			
Week 24	/ /	/ /	/ /			
Week 25	/ /	/ /	/ /			
Week 26	/ /	/ /	/ /	/ /	/ /	/ /

Walking Belt Replaced	/ /	Walking Platform Turned Over/Replaced	/ /
-----------------------	-----	---------------------------------------	-----

TROUBLESHOOTING

MAINTENANCE

Regular maintenance is important for optimal performance and to reduce wear. Inspect and properly tighten all parts each time the treadmill is used. Replace any worn parts immediately.

Regularly clean the treadmill and keep the walking belt clean and dry. First, **press the power switch into the off position and unplug the power cord.** Wipe exterior parts of the treadmill with a damp cloth and a small amount of mild soap. **IMPORTANT: Do not spray liquids directly onto the treadmill. To avoid damage to the console, keep liquids away from the console.** Then, thoroughly dry the treadmill with a soft towel.

TROUBLESHOOTING

Most treadmill problems can be solved by following the simple steps below. Find the symptom that applies, and follow the steps listed. If further assistance is needed, see the back cover of this manual.

SYMPTOM: The power does not turn on

- Make sure that the power cord is plugged into a properly grounded outlet (see page 14).
- After the power cord has been plugged in, make sure that the key is inserted into the console.
- Check the power switch located on the treadmill near the power cord. Make sure that the power switch is pressed into the on position.

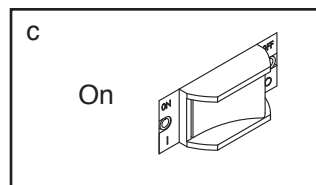

SYMPTOM: The power turns off during use

- Check the power switch (see drawing c at the left). If the switch has tripped, wait for five minutes and then press the switch to the on position.
- Make sure that the power cord is plugged in. If the power cord is plugged in, unplug it, wait for five minutes, and then plug it back in.
- Remove the key from the console, and then reinsert it.
- If the treadmill still will not run, please see the back cover of this manual.

SYMPTOM: The incline of the treadmill does not change correctly

- Calibrate the incline system (see THE MAINTENANCE MODE on page 18).

SYMPTOM: The walking belt is off-center or slips when walked on

- If the walking belt is off-center**, first remove the key and **UNPLUG THE POWER CORD.** **If the walking belt has shifted to the left**, use a hex key to turn the left idler roller screw clockwise 1/2 of a turn; **if the walking belt has shifted to the right**, turn the left idler roller screw counterclockwise 1/2 of a turn. Be careful not to overtighten the walking belt. Then, plug in the power cord, insert the key, and walk on the treadmill for a few minutes. Repeat until the walking belt is centered.

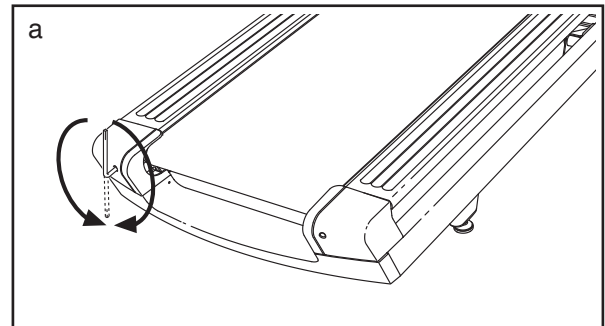

- b. **If the walking belt slips when walked on, first remove the key and UNPLUG THE POWER CORD.** To properly tighten the walking belt, see step 7 on page 23.

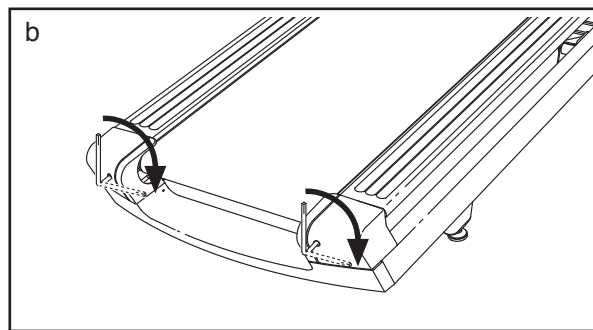

EXERCISE GUIDELINES

⚠️ WARNING: Before beginning this or any exercise program, consult your physician. This is especially important for persons over age 35 or persons with pre-existing health problems.

The heart rate monitor is not a medical device. Various factors may affect the accuracy of heart rate readings. The heart rate monitor is intended only as an exercise aid in determining heart rate trends in general.

These guidelines will help you to plan your exercise program. For detailed exercise information, obtain a reputable book or consult your physician. Remember, proper nutrition and adequate rest are essential for successful results.

EXERCISE INTENSITY

Whether your goal is to burn fat or to strengthen your cardiovascular system, exercising at the proper intensity is the key to achieving results. You can use your heart rate as a guide to find the proper intensity level. The chart below shows recommended heart rates for fat burning and aerobic exercise.

165	155	145	140	130	125	115	❤️
145	138	130	125	118	110	103	❤️
125	120	115	110	105	95	90	❤️
<hr/>							
20	30	40	50	60	70	80	

To find the proper intensity level, find your age at the bottom of the chart (ages are rounded off to the nearest ten years). The three numbers listed above your age define your “training zone.” The lowest number is the heart rate for fat burning, the middle number is the heart rate for maximum fat burning, and the highest number is the heart rate for aerobic exercise.

Burning Fat—To burn fat effectively, you must exercise at a low intensity level for a sustained period of time. During the first few minutes of exercise, your body uses carbohydrate calories for energy. Only after the first few minutes of exercise does your body begin to use stored fat calories for energy. If your goal is to burn fat, adjust the intensity of your exercise until your heart rate is near the lowest number in your training zone. For maximum fat burning, exercise with your heart rate near the middle number in your training zone.

Aerobic Exercise—If your goal is to strengthen your cardiovascular system, you must perform aerobic exercise, which is activity that requires large amounts of oxygen for prolonged periods of time. For aerobic exercise, adjust the intensity of your exercise until your heart rate is near the highest number in your training zone.

WORKOUT GUIDELINES

Warming Up—Start with 5 to 10 minutes of stretching and light exercise. A warm-up increases your body temperature, heart rate, and circulation in preparation for exercise.

Training Zone Exercise—Exercise for 20 to 30 minutes with your heart rate in your training zone. (During the first few weeks of your exercise program, do not keep your heart rate in your training zone for longer than 20 minutes.) Breathe regularly and deeply as you exercise; never hold your breath.

Cooling Down—Finish with 5 to 10 minutes of stretching. Stretching increases the flexibility of your muscles and helps to prevent post-exercise problems.

EXERCISE FREQUENCY

To maintain or improve your condition, complete three workouts each week, with at least one day of rest between workouts. After a few months of regular exercise, you may complete up to five workouts each week, if desired. Remember, the key to success is to make exercise a regular and enjoyable part of your everyday life.

SUGGESTED STRETCHES

The correct form for several basic stretches is shown at the right. Move slowly as you stretch—never bounce.

1. Toe Touch Stretch

Stand with your knees bent slightly and slowly bend forward from your hips. Allow your back and shoulders to relax as you reach down toward your toes as far as possible. Hold for 15 counts, then relax. Repeat 3 times. Stretches: Hamstrings, back of knees and back.

2. Hamstring Stretch

Sit with one leg extended. Bring the sole of the opposite foot toward you and rest it against the inner thigh of your extended leg. Reach toward your toes as far as possible. Hold for 15 counts, then relax. Repeat 3 times for each leg. Stretches: Hamstrings, lower back and groin.

3. Calf/Achilles Stretch

With one leg in front of the other, reach forward and place your hands against a wall. Keep your back leg straight and your back foot flat on the floor. Bend your front leg, lean forward and move your hips toward the wall. Hold for 15 counts, then relax. Repeat 3 times for each leg. To cause further stretching of the achilles tendons, bend your back leg as well. Stretches: Calves, achilles tendons and ankles.

4. Quadriceps Stretch

With one hand against a wall for balance, reach back and grasp one foot with your other hand. Bring your heel as close to your buttocks as possible. Hold for 15 counts, then relax. Repeat 3 times for each leg. Stretches: Quadriceps and hip muscles.

5. Inner Thigh Stretch

Sit with the soles of your feet together and your knees outward. Pull your feet toward your groin area as far as possible. Hold for 15 counts, then relax. Repeat 3 times. Stretches: Quadriceps and hip muscles.

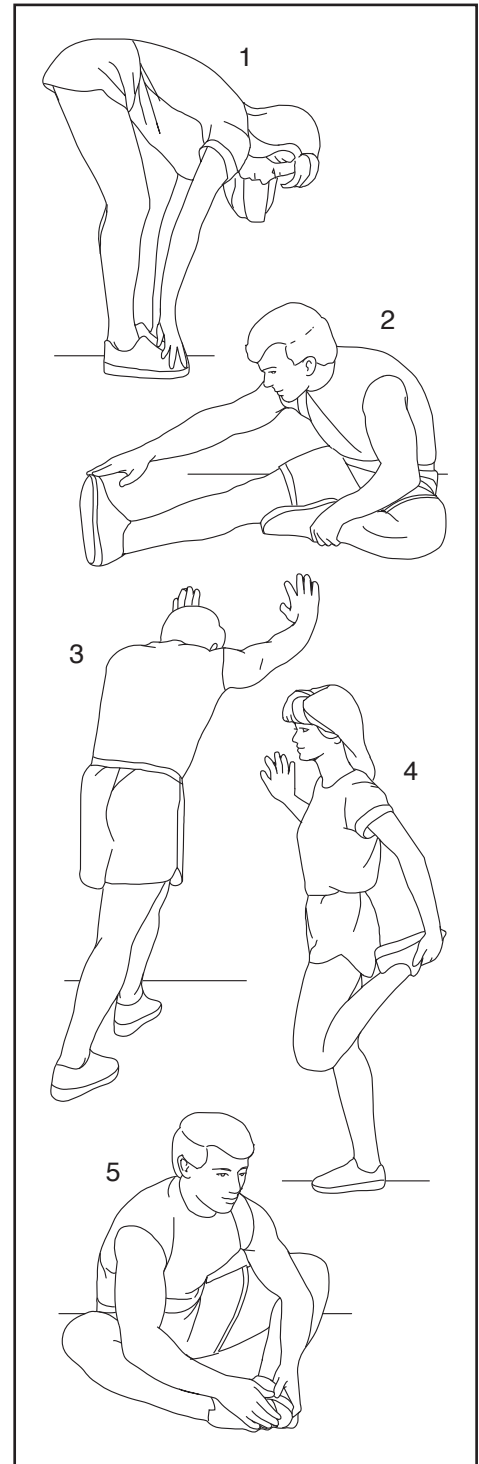

NOTES

PART LIST

Model No. FMTL39818.0 R1117A

Key No.	Qty.	Description	Key No.	Qty.	Description
1	4	3/8" x 3 1/4" Screw	51	4	#16 x 1 1/2" Screw
2	6	3/8" Star Washer	52	1	Converter Board
3	6	#8 x 5/8" Machine Screw	53	1	Frame
4	4	#8 x 3/8" Machine Screw	54	1	Drive Motor
5	8	3/8" x 1 3/4" Bolt	55	4	Motor Bushing
6	2	3/8" x 2 1/2" Bolt	56	1	Motor Mounting Plate
7	2	3/8" x 3" Screw	57	1	Motor Belt
8	4	5/16" x 1 1/2" Bolt	58	1	Left Rear Cap Insert
9	2	#8 Nut	59	1	Rear Cap
10	4	1/4" x 1 1/4" Screw	60	1	Left Cap Insert Bracket
11	4	3/8" x 4" Screw	61	1	Right Rear Cap Insert
12	12	#8 x 1/2" Wood Screw	62	1	Left Tray
13	2	1/2" x 3 1/2" Screw	63	1	Idler Roller
14	2	3/8" Pin	64	2	Leveling Foot
15	2	1/4" x 3/4" Cap Screw	65	1	5/16" Nut
16	2	5/16" x 1/2" Screw	66	1	Motor Hood
17	5	#8 x 1/2" Tek Screw	67	1	Front Cap
18	16	#8 x 5/8" Screw	68	1	Power Cord Bracket
19	2	Hood Base	69	1	Power Switch
20	4	1/2" Bushing	70	1	Power Cord
21	14	#8 x 1/2" Machine Screw	71	1	Receptacle
22	2	Hood Base Cushion	72	1	Left Side Cover
23	7	#8 x 3/4" Pan Head Tek Screw	73	1	Right Side Cover
24	13	#8 x 1/2" Screw	74	1	Incline Motor Bracket
25	2	1/2" Hairpin Cotter Pin	75	1	Roller Cover
26	2	3/8" Hairpin Cotter Pin	76	1	Incline Motor
27	4	3/8" x 2 3/4" Screw	77	2	Front Wheel
28	2	M3 Nut	78	1	Lift Frame
29	4	#10 x 3/4" Screw	79	2	Lift Frame Spacer
30	4	#8 Star Washer	80	1	Upright Cover
31	12	#4 x 5/16" Screw	81	1	Upright
32	5	3/8" Washer	82	1	Bottom Handrail Cover
33	2	3/8" Lock Washer	83	1	Handrail Frame
34	8	3/8" Nut	84	4	#10 Star Washer
35	8	1/4" x 3/4" Screw	85	4	Foot Rail Pad
36	4	#10 x 1" Screw	86	1	Handrail Cover
37	2	Cap Clip	87	1	Pulse Assembly
38	2	3/8" Locknut	88	1	Pulse Bar Crossbar
39	4	5/16" Flat Washer	89	2	Rear Roller Pivot Ring
40	1	5/16" x 3" Bolt	90	2	Side Cover Cap
41	1	1/2" x 2 1/4" Clevis Pin	91	1	Thermal Switch
42	1	1/2" x 1 3/4" Clevis Pin	92	1	Electronics Bracket
43	4	3/8" Flat Washer	93	1	Filter
44	1	Walking Platform	94	6	#6 x 1/4" Screw
45	1	Right Tray	95	1	Controller
46	1	Walking Belt	96	9	Cable Tie
47	1	Rear Platform Bracket	97	1	Console Frame
48	1	Front Platform Bracket	98	1	Console Back
49	2	Front Platform Cushion	99	1	Access Door
50	2	1/2" Nut	100	16	Foot Rail Bracket Spacer

Key No.	Qty.	Description	Key No.	Qty.	Description
101	1	Console Assembly	126	6	1/2" Standoff
102	1	Rear Resistor Bracket	127	10	#8 x 3/4" Washer Head Screw
103	1	Resistor	128	2	#6 x 1/2" Screw
104	1	Front Resistor Bracket	129	1	Right Cap Insert Bracket
105	1	Upright Collar	130	1	Fan Grill
106	6	#8 x 2" Screw	131	1	Switch Bracket
107	1	Key/Clip	132	1	Fan
108	4	Wheel Bushing	133	1	Drive Roller Pulley
109	4	Flat Wheel Bushing	134	4	Platform Cushion
110	2	Lift Motor Washer	135	1	Drive Motor Pulley
111	1	Upright Wire	136	2	#6 Nut
112	1	Power Cord Cover	137	6	5/16" x 1/2" Screw
113	1	Drive Roller	138	2	1/4" x 1/2" Screw
114	2	Foot Rail	139	1	3/8" x 4 1/2" Bolt
115	2	1/2" Washer	140	1	3/8" x 2 3/8" Screw
116	1	15 1/2" Wire Tie	141	2	3/8" Jam Nut
117	1	Large Warning Decal	142	1	Idler Pulley
118	2	Wheel Axle	143	1	Idler Arm
119	2	Caution Decal	144	2	Snap Ring
120	2	Voltage Warning Decal	145	1	Idler Arm Pin
121	1	Console Bracket	146	1	M3 x 8mm Bolt
122	2	#8 x 1/2" Pan Head Screw	147	1	M3 x 25mm Bolt
123	4	3/8" Plastic Bushing	148	4	Foot Rail Bracket
124	6	#8 x 3/4" Screw	*	-	User's Manual
125	2	Platform Bracket Bushing			

Note: Specifications are subject to change without notice. For information about ordering replacement parts, see the back cover of this manual. *These parts are not illustrated.

EXPLODED DRAWING A

Model No. FMTL39818.0 R1117A

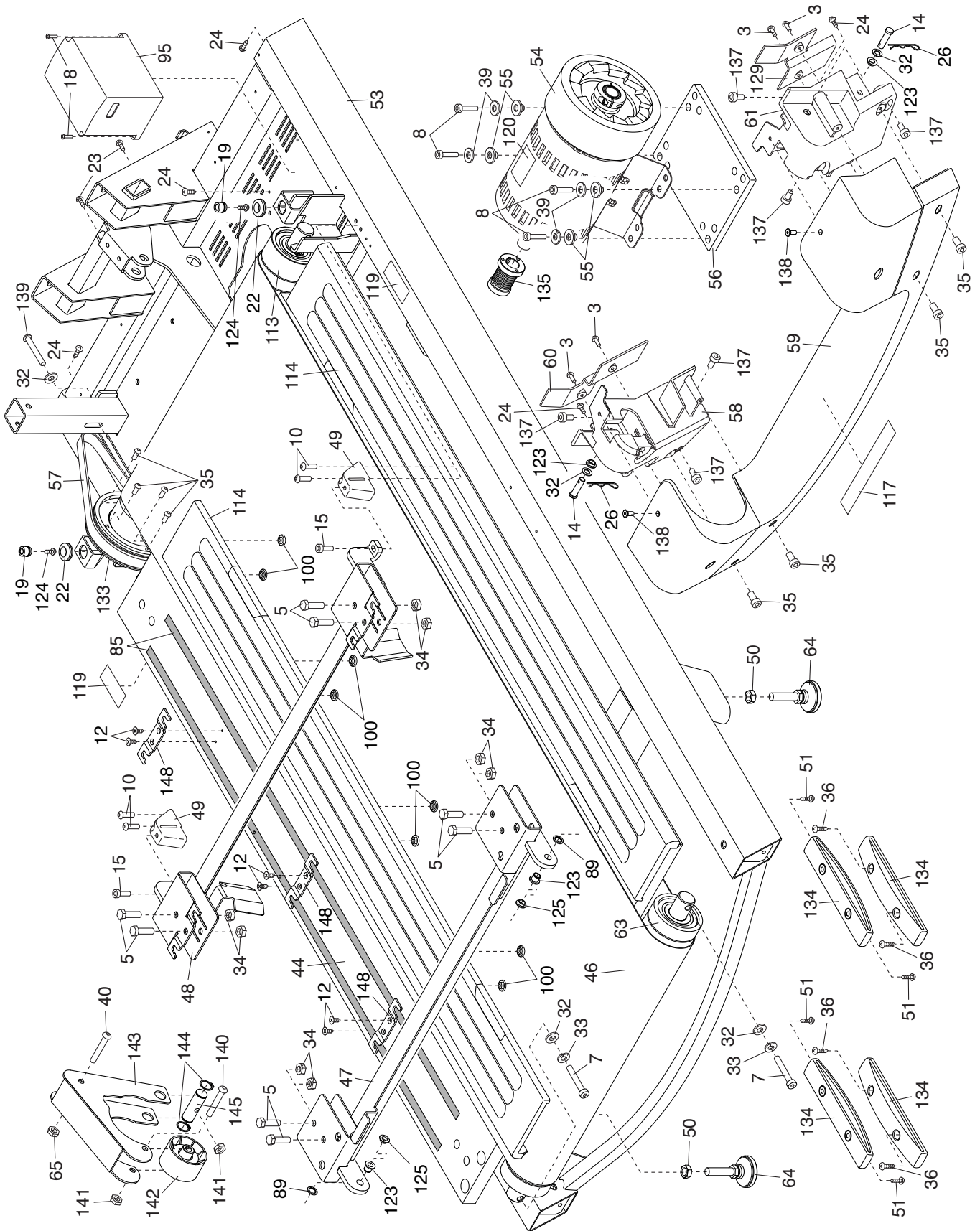

EXPLODED DRAWING B

Model No. FMTL39818.0 R1117A

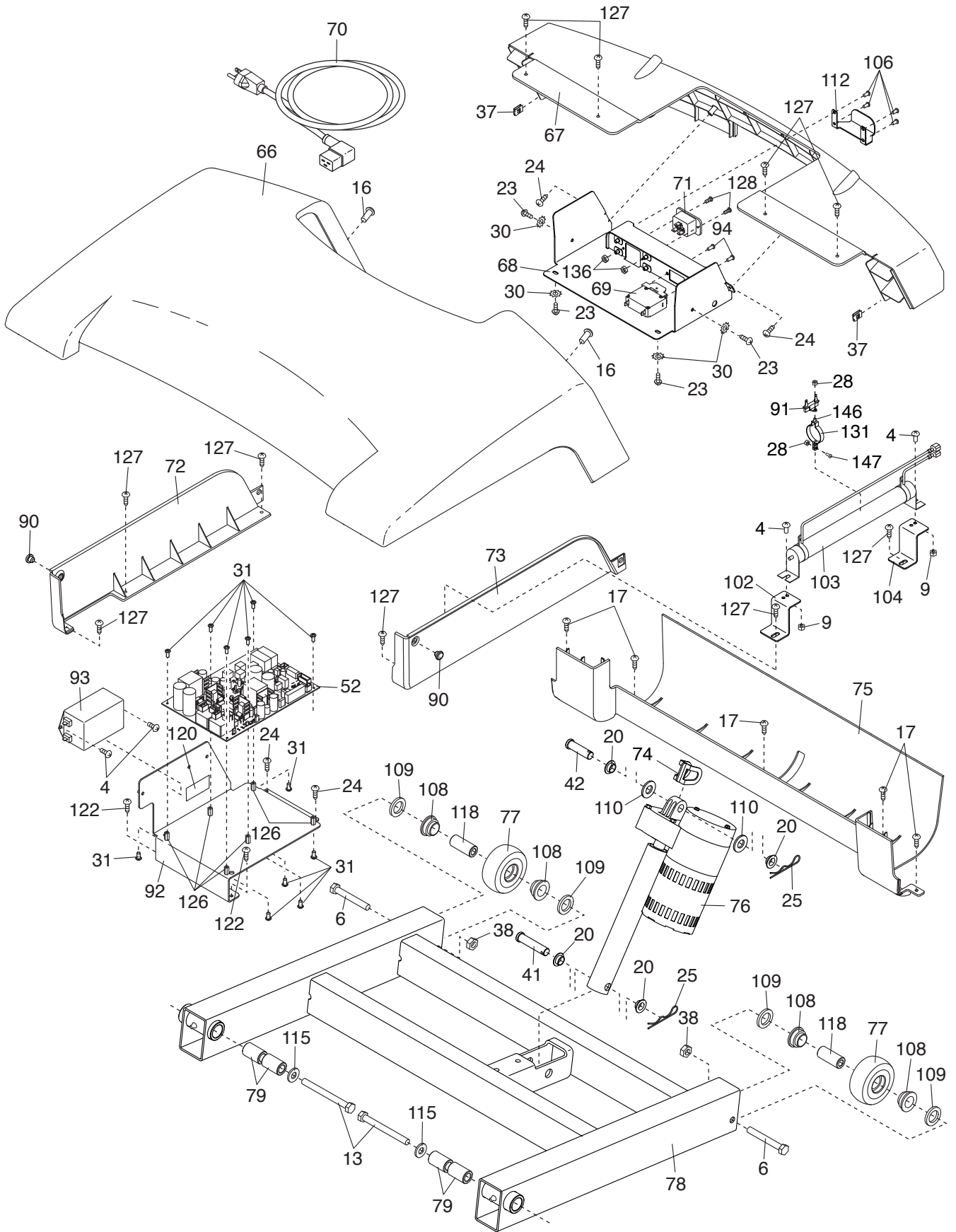

EXPLODED DRAWING C

Model No. FMTL39818.0 R1117A

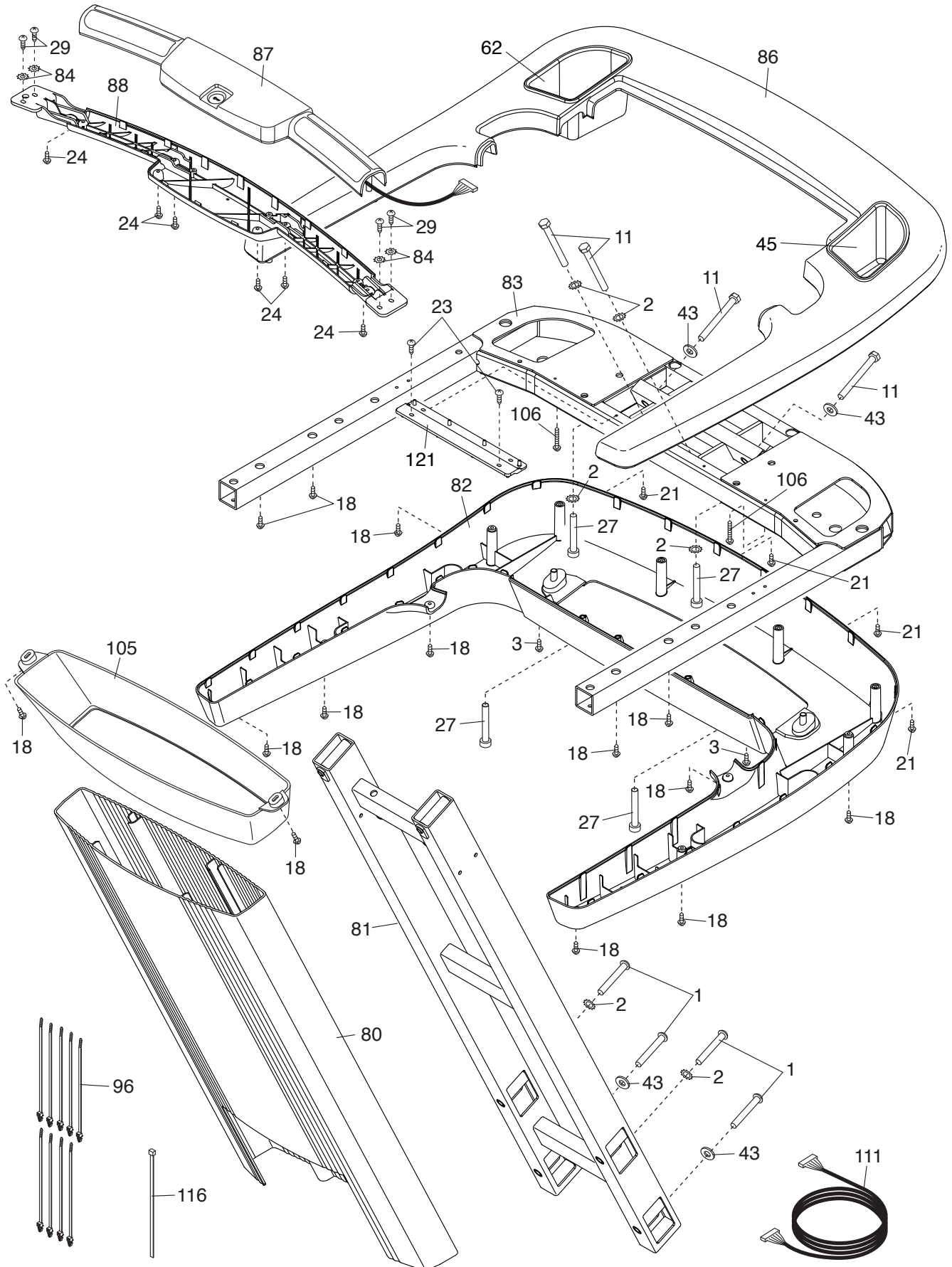

EXPLODED DRAWING D

Model No. FMTL39818.0 R1117A

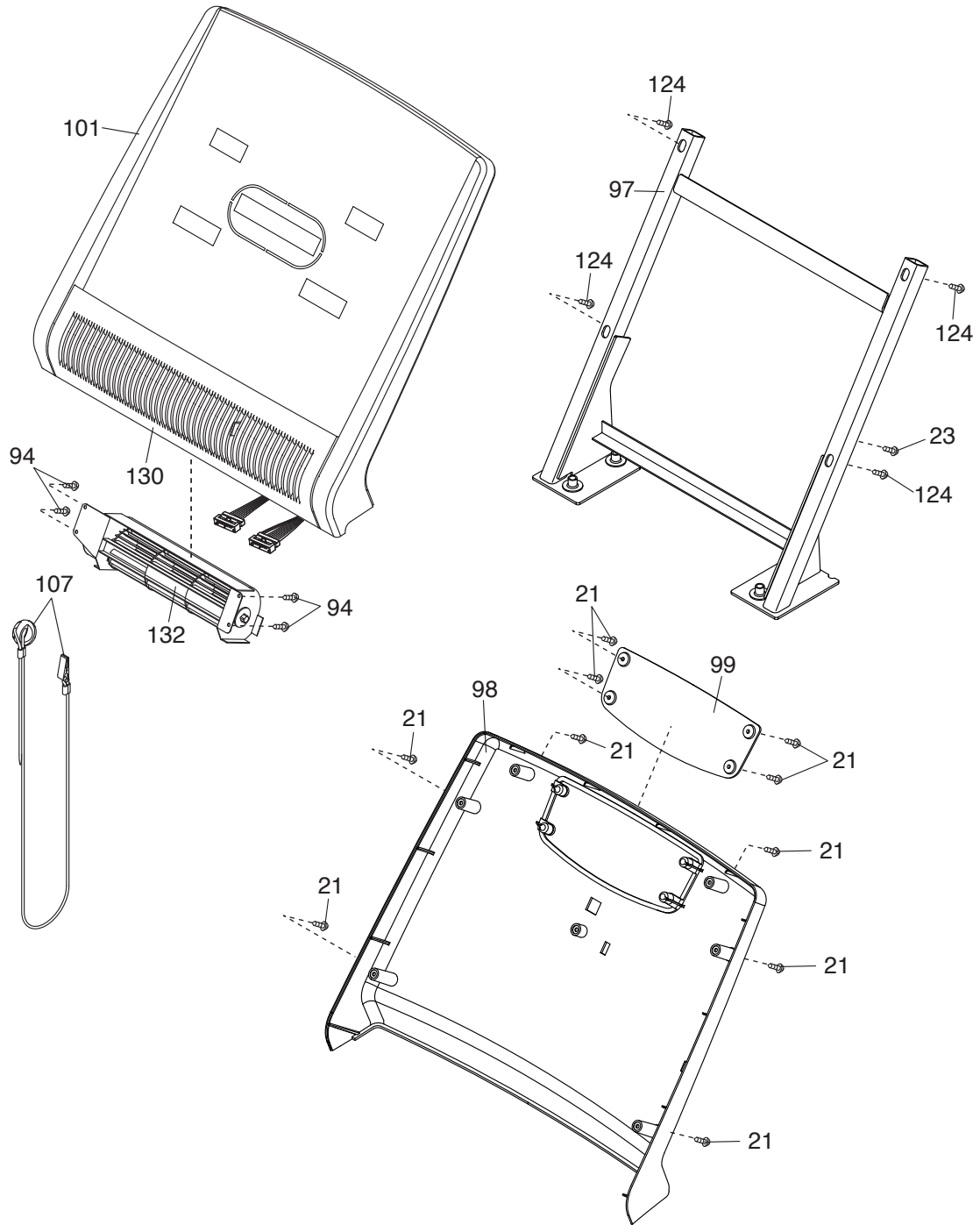

HOW TO CONTACT CUSTOMER CARE

If you have questions after reading this manual, or if parts are damaged or missing, please contact Customer Care at one of the phone numbers or addresses listed below. **Please note the model number, serial number, and name of the product (see the front cover of this manual) before contacting Customer Care. If you are ordering replacement parts, please also note the key number and description of each part (see the PART LIST and the EXPLODED DRAWING near the end of this manual).**

In the United States

Call: 1-800-201-2109 Mon.–Fri. 6 a.m.–6 p.m. MT

Email: customercare@freemotionfitness.com

Write:

FreeMotion Fitness

1500 South 1000 West

Logan, UT 84321-9813

United States

Outside the United States

Call: 001-800-527-5417 or 001-435-786-3521

Mon.–Fri. 6 a.m.–3 p.m. USA Mountain Time

Email: intlcustomercare@freemotionfitness.com

LIMITED WARRANTY

WARRANTY PERIODS AND COVERAGE

FreeMotion Fitness warrants this product to be free from defects in workmanship and material under normal use and service conditions. Parts and labor are warranted for one (1) year, unless otherwise specified on the invoice.

The warranty period commences on the invoice date of purchase. Any parts repaired or replaced during this warranty period will be warranted for the remainder of the original warranty period.

CONDITIONS AND LIMITATIONS

The following will void the warranty on this product:

1. This warranty applies only to the original owner and is non-transferable.
2. The labor warranty applies only to products sold in the US and Canada. Contact your authorized FreeMotion Fitness dealer for details on labor coverage in your country.
3. Any misuse, abuse, or improper service.
4. Users who weigh more than 400 lbs. (181 kg).
5. Damage caused by moving the product or improper storage including moving or storing the product on its side.
6. Use or storage of the product outdoors or in high-humidity environments including spa and pool areas.
7. Damage caused by improper wiring or insufficient electrical current. Note: This product may not have wiring.

This warranty shall not apply to the following:

1. Cosmetic items including grips, seats, decals, and labels.

2. Pick-up, delivery, or freight charges involved with a repair.
3. Any problem as a result of improper assembly or delivery.

WHAT TO DO IF SERVICE IS REQUIRED

FreeMotion Fitness warranty service may be obtained by contacting the authorized dealer from which you purchased this product. Make sure to retain your original invoice and serial number information. If this product experiences a failure under the warranty terms set forth, FreeMotion Fitness shall provide at their option either repair, replacement, or refund of the purchase price. FreeMotion Fitness compensates service providers for warranty trips within their service area. You may be charged additionally for service calls beyond this service area.

FreeMotion Fitness is not responsible or liable for indirect, special, or consequential damages arising out of or in connection with the use or performance of the product; damages with respect to any economic loss, loss of property, loss of revenues or profits, loss of enjoyment or use, or cost of removal or installation; or other consequential damages. Some regions do not allow the exclusion or limitation of consequential damages. Accordingly, the above limitation may not apply to you. This warranty gives you specific rights, and you may have other rights that vary from region to region.

TO CONTACT FREEMOTION FITNESS

See HOW TO CONTACT CUSTOMER CARE above.